



UGE WEATHER STATION

WIND AND AIR PRESSURE

Operation Manual

## ABOUT THIS MANUAL

Thank you and congratulations on selecting the *Urban Green Energy* weather station!

We are positive you will enjoy the benefits of accurate weather readings and the precise radio controlled time information that our instruments offer. In particular, the included anemometer will highlight the opportunity of installing a Wind Turbine.

This manual will guide you step-by-step through setting up your device. Use this manual to become familiar with your weather station, and save it for future reference.

Sincerely,  
The Urban Green Energy Team

# SUMMARY

- About this manual.....2
- LCD Display .....5
- Set up Guide.....6
  - Setting up the base station and transmitter .....6
  - Register transmitter .....6
  - Mounting the sensor .....7
  - Positioning .....10
- Program Mode.....11
  - Time .....11
  - Date.....11
  - Wind .....12
  - Rain .....12
  - Pressure.....12
  - Weather forecast tendency.....13
  - Indoor temperature .....14
  - Indoor humidity .....14
  - Outdoor temperature.....15
  - Outdoor humidity.....15
  - Memory modes.....15
  - Reset to Factory Default Settings.....16
- PC Connection .....16
  - Data Storage.....16
  - Data Recall.....16
  - Connections and Software.....16
  - PC software installation .....16
- Specifications .....19
- EasyWeather PC Software User Manual .....21
  - 1. General Information .....21
  - 2. System Requirements .....21
  - 3. Installation of the “EasyWeather” Software.....21
  - 4. Basic Settings of the “EasyWeather” Software.....21
  - Function button:.....23
  - What to do if graph function is not working .....30

## Glossary of Common Terms

### **LCD**

“LCD” is an acronym for “Liquid Crystal Display”. This is a common type of display screen used in televisions, computers, watches, and digital clocks.

### **BAROMETER & BAROMETRIC PRESSURE**

A barometer is a device that measures the pressure of the air pushing on it.

### **RELATIVE AIR PRESSURE**

The calculation of relative air pressure is a combination of the absolute air pressure and the altitude.

### **ABSOLUTE AIR PRESSURE**

Absolute air pressure is the actual air pressure on the barometer independent of altitude.

### **INCHES OF MERCURY (inHg)**

Inches of Mercury are the common units of measurement for air pressure in the United States.

### **HECTOPASCALS (hPa)**

Hectopascals are the common units of measurement for air pressure in the International System (SI) of measurement. A hectopascal holds the same value.

### **Important Note:**

Before inserting batteries, please carefully read the operation manual.

The Professional weather station includes a base station (receiver), a transmitter unit, one wind direction sensor, one wind speed sensor, one rain gauge, USB cable and a PC software package on CD-ROM.

**An added feature of the UGE Weather Station is the readout of all measured and displayed time and weather data on a PC.**

## LCD DISPLAY

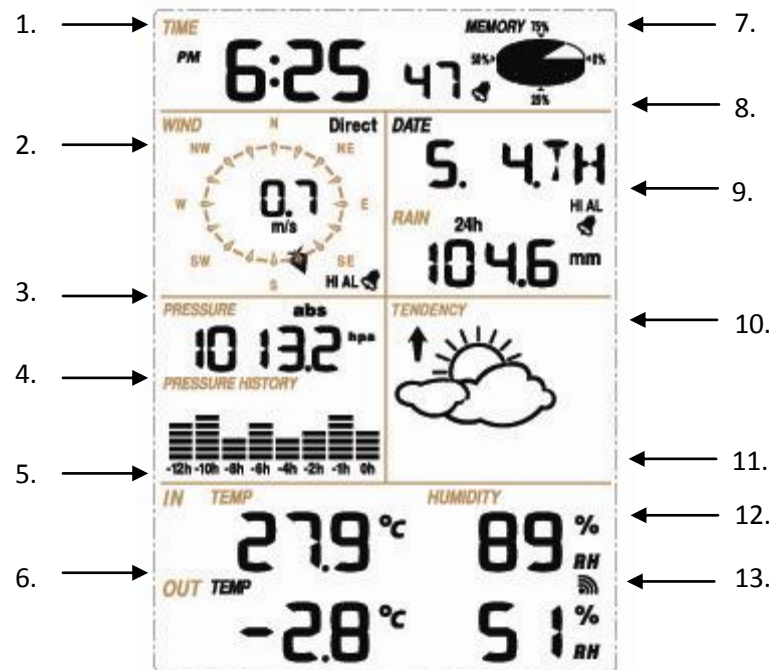

1. Time
2. Wind direction
3. Barometric Pressure
4. Barometric trend
5. Indoor Temperature
6. Outdoor Temperature
7. Memory
8. Date
9. Rainfall
10. Weather Forecast
11. Indoor Humidity
12. Outdoor reception signal
13. Outdoor Humidity

**Note:** The presence of the "Alarm-On icon" in the section means that the particular alarm has been enabled.

## SET UP GUIDE

Before placing and installing all components of the weather station at their final destination, please set up the weather station with all parts being nearby for testing the correct function.

### SETTING UP THE BASE STATION AND TRANSMITTER

Insert two pieces of LR6 (AA size) batteries into the transmitter, the LED located in the middle front case of transmitter will be turned on for 4 seconds, after which the transmitter will be functioning. When data is being transmitted the LED will flash for 20ms intervals.

After inserting the batteries into the Weather Station, all LCD segments will be turned on for a few seconds.

The weather station will make initial measurements and start to register the transmitter. Do not press any key before outdoor sensor data is received, otherwise the outdoor sensor learning mode will be terminated. When outdoor transmitter has been registered, the base station will automatically switch to the normal display mode from which all further settings can be performed by the user.

### REGISTER TRANSMITTER

If no outdoor weather data is displayed or the signal to the sensors is lost during setting up, mounting, changing of batteries to the sensor or plugging or unplugging cables, simply press and hold the DOWN/- key for 4 seconds and a short beep will sound to synchronize the base stations to sensors. Weather data will not be received without synchronization.

**Note:**

Commonly the radio communication between receiver and transmitter in the open field can reach a distance of up to 330 feet providing that there are no interfering obstacles such as buildings, trees, vehicles, high voltage lines, etc.

Radio interferences such as PC screens, radios or TV sets can, in bad cases, entirely cut off radio communication. Please take this into consideration when choosing standing or mounting locations.

## MOUNTING THE SENSOR

### **Important Notes:**

On the edge of wind direction sensor, there are four alphabet letter of “N”, “E”, “S” and “W” representing the directions North, East, South and West. Wind direction sensor has to be adjusted so that the directions on the sensor are matched with your real location. Permanent wind direction error will be introduced when the wind direction sensor is not orientated correctly during installation.

Wind speed sensor wire has to be inserted into the phone jacket on wind direction sensor. Wind direction sensor wire has to be inserted into the phone jacket located on the thermo-hygro sensor with marking of “Wind” on top.

The rain sensor wire has to be inserted into the phone jacket located on the thermo-hygro sensor with marking of “Rain” on top.

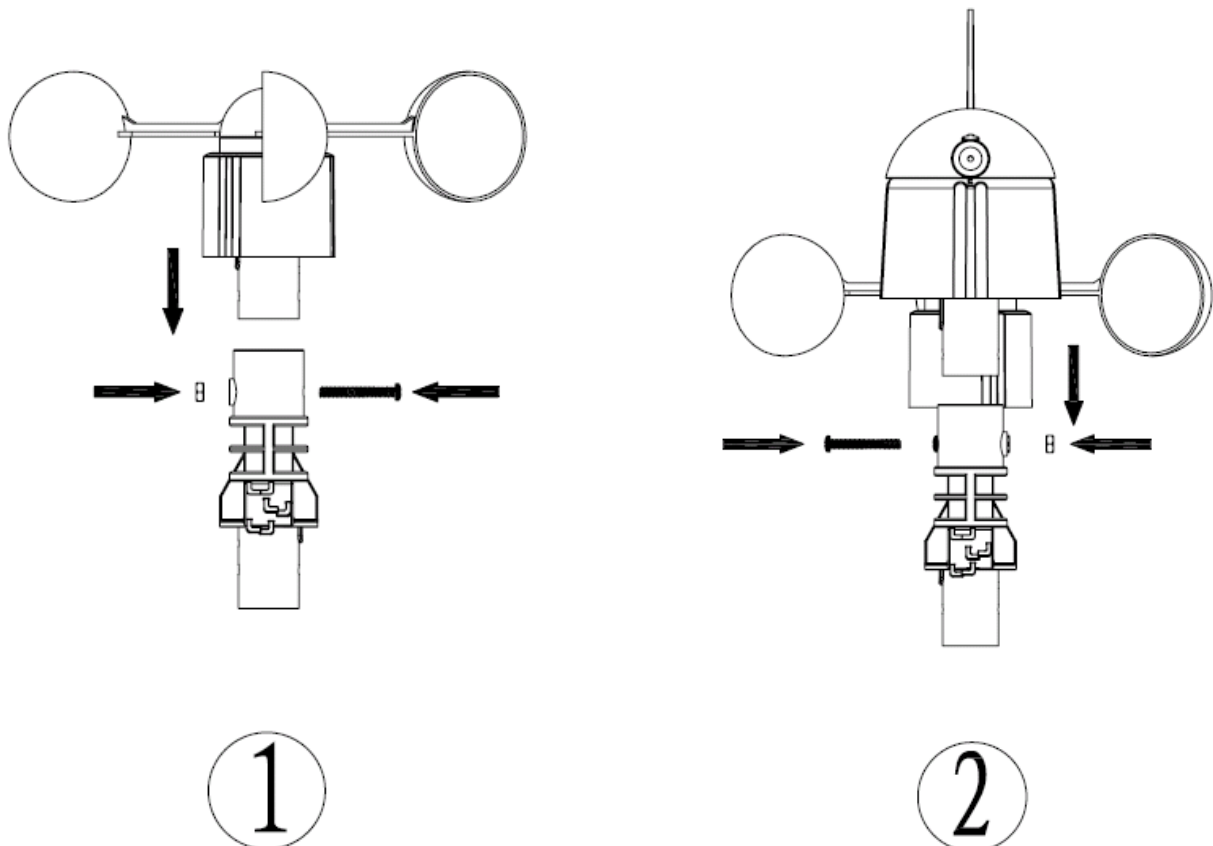

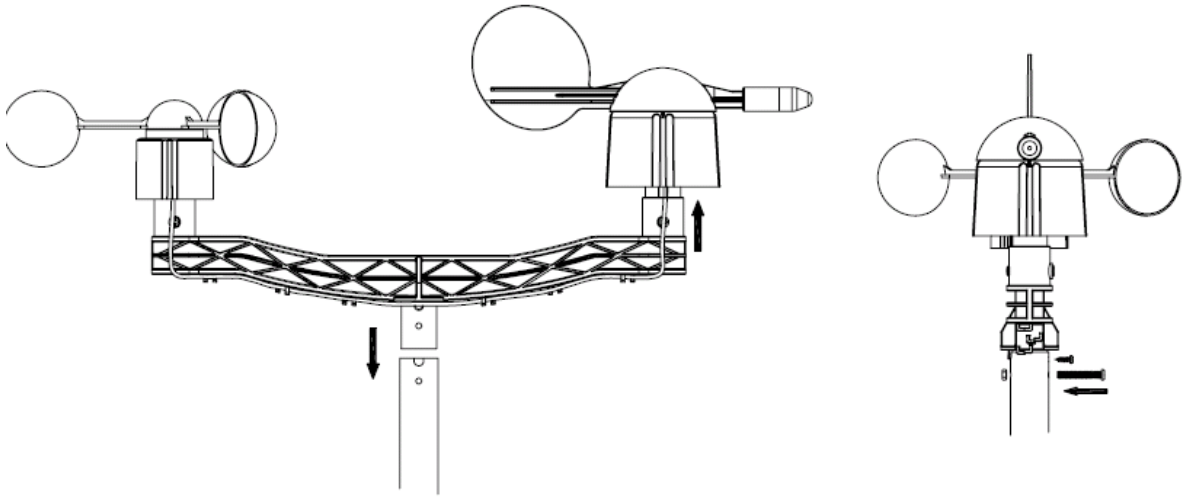

3

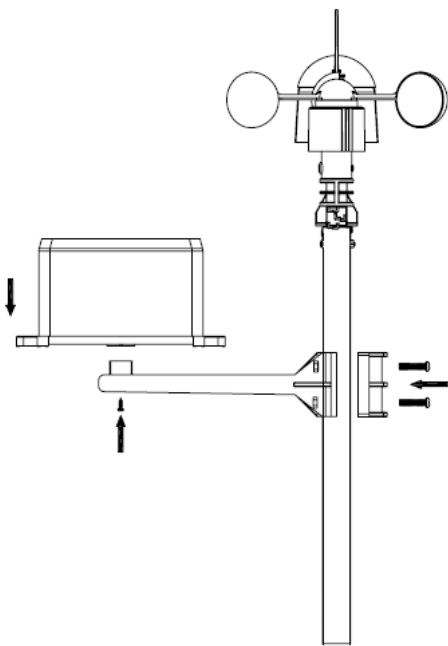

4

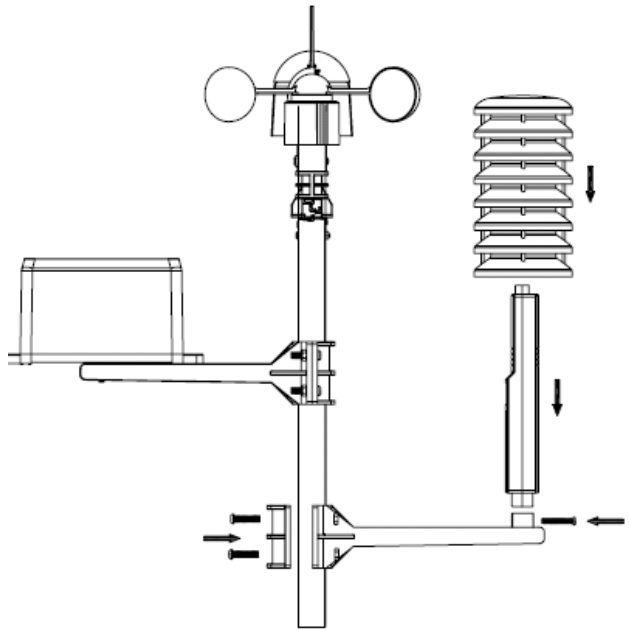

5

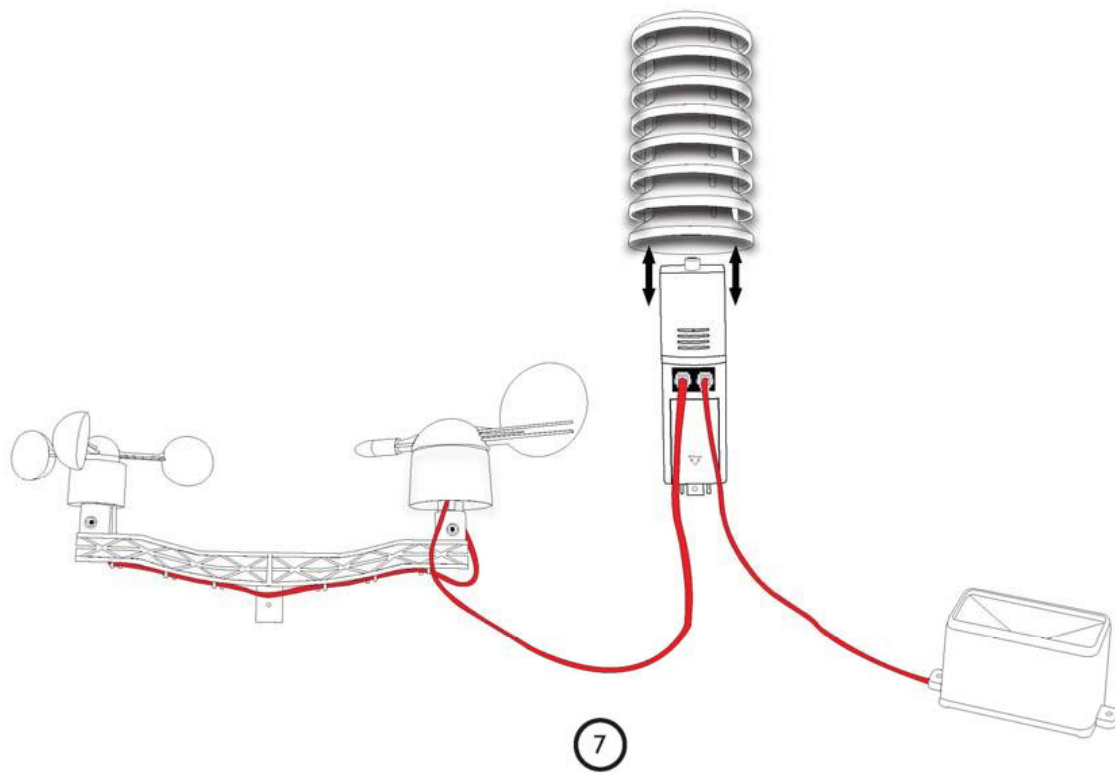
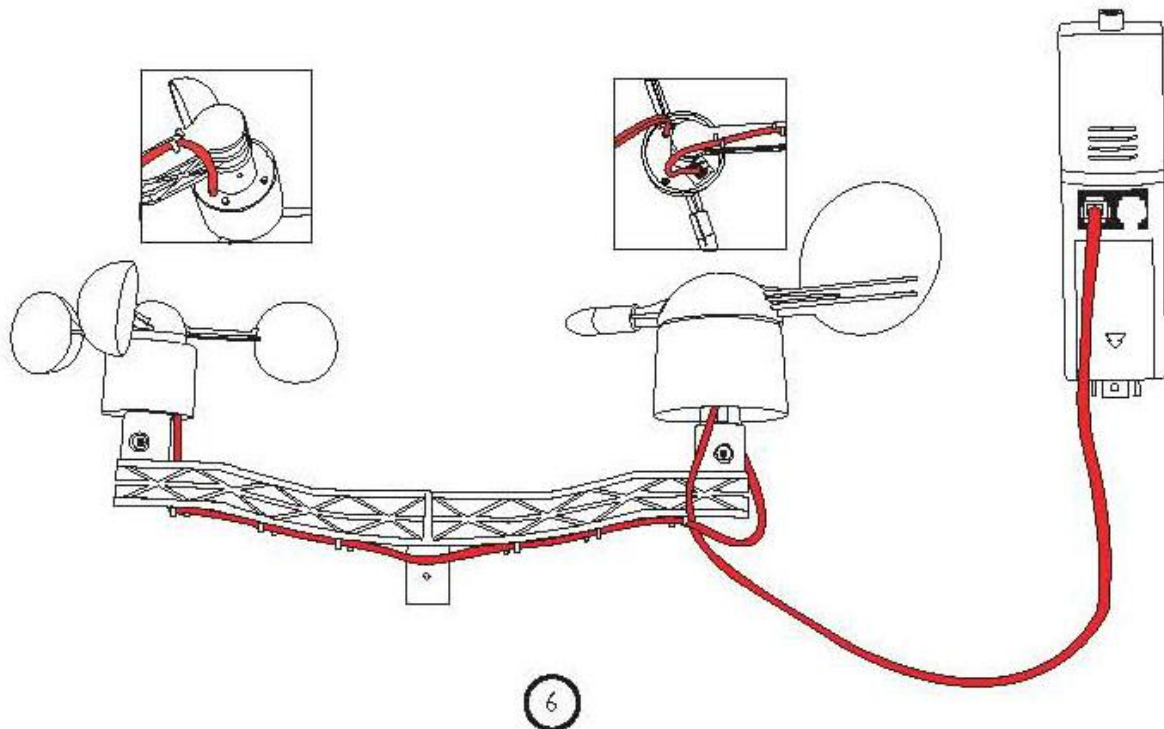

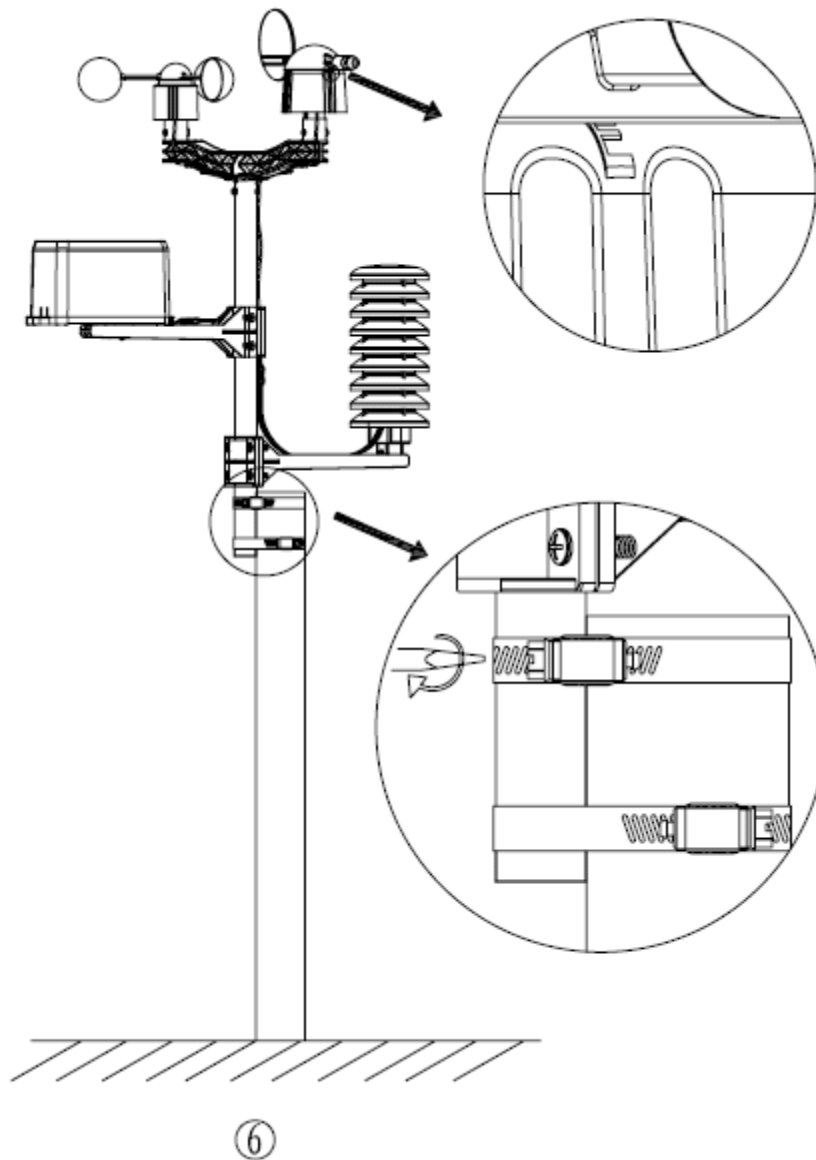

## POSITIONING

Once you have verified that all of the components of the weather station are working, they can be positioned in their permanent places. Before permanently mounting, make sure that all components work properly together at their chosen mounting or standing locations. If for example there appears to be problems with the 433 MHz radio transmission, it can generally be overcome by moving the mounting locations.

## PROGRAM MODE

The base station has six keys for easy operation: **MENU** key, **UP/+** key, **DOWN/-** key, **ENTER** key, **HISTORY** key, **ON/OFF** key

**Note:** Because of the default settings already determined by the manufacturer it may not be necessary for the majority of user to perform-except the relative pressure(see further down)-any further basic settings and changes, however, can be easily made.

**Note:** Keeping the **UP/+** or **DOWN/-** key depressed when setting certain units in the manual setting mode will increase/decrease digits in greater steps.

The setting procedure can be exited at any time by either pressing the **HISTORY** key or waiting for the 30-second time-out to take effect.

The basic settings can now be performed in the following order:

### TIME



- Press the **MENU** key to select the TIME section, TIME section digits will start flashing. Enter LCD contrast setting mode (level 1-8, default level 5), press the **UP/+** or **DOWN/-** key to set the value.

- Press the **ENTER** key to select the following modes:

- Time zone  
**Note:** At Europe, 0 for GMT+1 time zone, 1 for GMT+2 time zone, -1 for GMT time zone. At America, -4 for Atlantic time zone, -5 for Eastern Time zone, -6 for Central Time Zone, -7 for Mountain Time zone, -8 for Pacific time zone, -9 for Alaska time zone, -10 for Hawaii time zone.
- 12/24h time display select (default 12 hours)
- Manual time setting (hours/minutes)

Press the **UP/+** or **DOWN/-** key to set the value.

### DATE

**DATE**

The image shows the LCD display with the word 'DATE' at the top. Below it, the digits '1. 1.09' are displayed, where the first '1.' is larger than the second '1.09'.

- Press the **MENU** key twice to select the DATE section, DATE section digits will start flashing. Enter DD-MM-YY/DD-MM-WEEK/Time alarm display mode. (Default DD-MM-YY format), press the **UP/+** or **DOWN/-** key to set the value.

- Press the **ENTER** key to select the following modes, press the **UP/+** or **DOWN/-** key to set the value:

- Select DD-MM or MM-DD format. (Default DD-MM format)
- Calendar setting (year/month/date)
- Time alarm setting. (Hours/minutes). Press the **ON/OFF** key to on/off the alarm. If alarm is enabled, an alarm symbol  appears in the display indicating the alarm function has been enabled.

**Note:** When a set weather alarm condition has been triggered that particular alarm will sound for

120 seconds. The corresponding value, ‘HI AL’ or ‘LO AL’ and the alarm symbol are flashing until the weather condition doesn’t meet the user set level. Press any key to mute the alarm.

## WIND

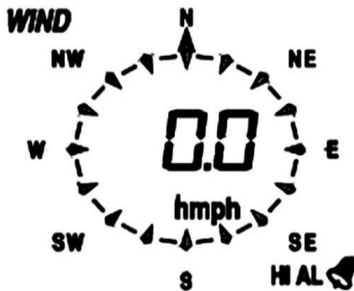

- Press the **MENU** key the third time to select the WIND section, WIND section digits will start flashing. Enter average wind speed / Gust display mode. (Default average wind speed), press the **UP/+** or **DOWN/-** key to select the display.

- Press **ENTER** key to select the following modes, then press the **UP/+** or **DOWN/-** key to select the display or set the value:

- Select the wind speed unit between km/h, mph, m/s, knots, bft. (Default mph)
- The wind speed high alarm setting.
- The wind direction alarm setting.
- Reset the maximum wind speed value. When both the wind speed value and MAX icon are flashing, hold the **ENTER** key for 3s, the maximum value will be reset to current reading.

Note: Press the **ON/OFF** key to on/off the alarm. If alarm is enabled, an alarm symbol  appears in the display indicating the alarm function has been enabled

## RAIN

**RAIN 1h**



- Press the **MENU** key the fourth time to select the RAIN section, RAIN section digits will start flashing. Enter rain display mode (1h, 24h, week, month and total rain. Default 1h), press the **UP/+** or **DOWN/-** key to select the display.



- Press **ENTER** key to select the following modes, then press the **UP/+** or **DOWN/-** key to select the display or set the value:

- Select rain fall unit between mm, inch. (Default mm)
- The rain high alarm setting. Press the **ON/OFF** key to on/off the alarm. If alarm is enabled, an alarm symbol  appears in the display indicating the alarm function has been enabled
- Reset the maximum rainfall value. When both the rain value and MAX icon are flashing, hold the **ENTER** key for 3s, the maximum rain value will be reset to current reading.
- Clear the total rainfall. When both the total rain value and CLEAR word are flashing, hold the **ENTER** key for 3s, the total value will be reset to zero. 1h, 24h, weeks, month rain value will be reset to zero automatically.

## PRESSURE

**PRESSURE**      **abs**  
 HI AL **10 13.2** hpa  
**PRESSURE HISTORY**



- Press the **MENU** key the fifth time to select the PRESSURE section, PRESSURE section digits will start flashing. Enter the pressure display mode (relative and absolute pressure. Default absolute pressure), press the **UP/+** or **DOWN/-** key to select the display.
- Press **ENTER** key to select the following modes, then press the **UP/+** or **DOWN/-** key to select the display or set the value:
  - Select pressure unit between hPa, mmHg, inHg. (Default hPa).
  - The relative pressure setting. (If select absolute pressure display, skip this step)
  - The pressure high alarm setting. Press the **ON/OFF** key to on/off the alarm. If alarm is enabled, an alarm symbol  appears in the display indicating the alarm function has been enabled
  - The pressure low alarm setting. Press the **ON/OFF** key to on/off the alarm. If alarm is enabled, an alarm symbol  appears in the display indicating the alarm function has been enabled
  - Reset the maximum pressure value. When both the pressure value and MAX icon are flashing, hold the **ENTER** key for 3s, the maximum pressure value will be reset to current reading.
  - Reset the minimum pressure value. When both the pressure value and MIN icon are flashing, hold the **ENTER** key for 3s, the minimum pressure value will be reset to current reading.

### Pressure history bar graph

Press the **MENU** key the sixth time to select the PRESS HISTORY section, PRESSURE HISTORY section digit will start flashing. Press the **UP/+** or **DOWN/-** key to select the bar graph time scale between 12hrs and 24 hrs for pressure history.

## WEATHER FORECAST TENDENCY

### TENDENCY



- Press the **MENU** key the seventh time to select the TENDENCY section, TENDENCY section digits will start flashing. Enter the weather forecast tendency display mode (SUNNY, PARTLY CLOUDY and CLOUDY, RAINY/SNOW icon), press the **UP/+** or **DOWN/-** key to select the display.
- Press **ENTER** key to select the following modes, then press the **UP/+** or **DOWN/-** key to select the display or set the value:
  - Set the pressure threshold from 2-4hPa(default 2hPa)
  - Set the storm threshold from 3-9hPa(default 4hPa)

Notes to pressure sensitivity setting for weather forecasting:

The pressure threshold can be set to suit the user's requirement for weather forecasting from 2-4hPa (default 2hPa). For areas that experience frequent changes in air pressure requires a higher hPa setting compared to an area where the air pressure is stagnant. For example if 4hPa is selected, then there must be a fall or rise in air pressure of at least 4hPa needed to change the weather forecast icons.

Notes to storm threshold setting

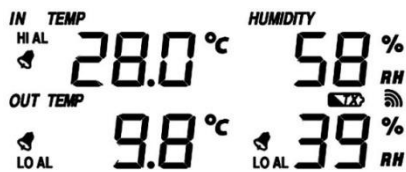

The storm threshold means the weather icons (rain and clouds) will begin to flash indicating a dramatic change in pressure, indicating a storm. Similar to the general pressure sensitivity setting it is possible to adjust the storm threshold sensitivity from 3-9hPa (default 4hPa). When there is a fall over pressure threshold within 3 hours, the storm forecasting will be activated, the clouds with rain icon and tendency arrows will flash for 3 hours indicating the storm warning feature has been activated.

## INDOOR TEMPERATURE



- Press the **MENU** key the eighth time to select the INDOOR TEMPERATURE section, INDOOR TEMPERATURE section digits will start flashing. Enter the temperature unit mode, press the **UP/+** or **DOWN/-** key to select temperature unit between °C and °F

- Press **ENTER** key to select the following modes:

- The indoor temperature high alarm setting. Press the **ON/OFF** key to on/off the alarm. If alarm is enabled, an alarm symbol  appears in the display indicating the alarm function has been enabled
- The indoor temperature low alarm setting. Press the **ON/OFF** key to on/off the alarm. If alarm is enabled, an alarm symbol  appears in the display indicating the alarm function has been enabled
- Reset the maximum indoor temperature value. When both the indoor temperature value and MAX icon are flashing, hold the **ENTER** key for 3s, the maximum indoor temperature value will be reset to current reading.
- Reset the minimum indoor temperature value. When both the indoor temperature value and MIN icon are flashing, hold the **ENTER** key for 3s, the minimum indoor temperature value will be reset to current reading.

## INDOOR HUMIDITY

- Press the **MENU** key the ninth time to select the INDOOR HUMIDITY section, INDOOR HUMIDITY section digits will start flashing. Enter the indoor humidity high alarm setting mode, press

the **ON/OFF** key to on/off the alarm. If alarm is enabled, an alarm symbol  appears in the display indicating the alarm function has been enabled

- Press **ENTER** key to select the following modes:



- The indoor humidity low alarm setting. Press the **ON/OFF** key to on/off the alarm. If alarm is enabled, an alarm symbol  appears in the display indicating the alarm function has been enabled
- Reset the maximum indoor humidity value. When both the indoor humidity value and MAX icon are flashing, hold the **ENTER** key for 3s, the maximum indoor humidity value will be reset to current reading.
- Reset the minimum indoor humidity value. When both the indoor humidity value and MIN icon are flashing, hold the **ENTER** key for 3s, the minimum indoor humidity value will be reset to current reading.

## OUTDOOR TEMPERATURE

- Press the **MENU** key the tenth time to select the OUTDOOR TEMPERATURE section, OUTDOOR

TEMPERATURE section digits will start flashing. Enter the outdoor temperature display mode, press the **UP/+** or **DOWN/-** key to Select the outdoor temperature display between Outdoor Temperature, Wind Chill and Dew Point.

- Press **ENTER** key to select the following modes:

- Temperature unit display. Press the **UP/+** or **DOWN/-** key to select the temperature unit between °C and °F by
- The outdoor temperature high alarm setting. Press the **ON/OFF** key to on/off the alarm. If alarm is enabled, an alarm symbol  appears in the display indicating the alarm function has been enabled
- The outdoor temperature low alarm setting. Press the **ON/OFF** key to on/off the alarm. If alarm is enabled, an alarm symbol  appears in the display indicating the alarm function has been enabled
- Reset the maximum outdoor temperature value. When both the outdoor temperature value and MAX icon are flashing, hold the **ENTER** key for 3s, the maximum outdoor temperature value will be reset to current reading.
- Reset the minimum outdoor temperature value. When both the outdoor temperature value and MIN icon are flashing, hold the **ENTER** key for 3s, the minimum outdoor temperature value will be reset to current reading.

## OUTDOOR HUMIDITY

- Press the **MENU** key the eleventh time to select the OUTDOOR HUMIDITY section, Procedures and settings are similar to Indoor humidity

## MEMORY MODES

1) Press the HISTORY key to activate history data toggle display, Press **DOWN/-** key to toggle forward to see earlier weather history data together time stamp, press **UP/+** key to see later history weather data. When history data displayed, the corresponding time will be displayed at the time

section area (History data saving interval can only be changed using the PC software that comes with this product, the default history data saving time interval is preset to 30 minutes prior to shipment).

2) Press the HISTORY key again will trigger the memory clear procedure: the word of “CLEAR” will be flashing; the full memory usage icon will be flashing. Hold the ENTER key for 3 seconds will clear the memory.

## RESET TO FACTORY DEFAULT SETTINGS

While in normal display, press and hold the **UP/+** key for 20seconds to reset all settings to the manufacturer default settings.

## PC CONNECTION

**As an important feature in addition to the display, the Weather Station allows the read-out of all measured and displayed time and weather data in form of complete history data sets on a PC.**

## DATA STORAGE

For a comprehensive weather history, the Base Station allows the internal storage of up to 4080 complete sets of weather data with time and date. The base station will lose all weather data if an interruption of power supply. In case the memory capacity of the Weather Station is exhausted the oldest data sets stored will be overwritten by the new ones entered.

## DATA RECALL

Certain weather data or setting values can only be read out, processed, and displayed by means of a PC. Also the settings of the storing intervals from 5 minutes to 240 minutes for the storage of data sets can only be performed by means of a PC.

## CONNECTIONS AND SOFTWARE

Weather Station and PC are connected via a USB cable. The EasyWeather software package, also included in the shipping contents, must be installed on the PC.

This software allows the display of all present weather data with graphic symbols. It also allows the display, storage, and printing of history data sets, whose volume exceeding the maximum 4080 data sets of the Weather Station is only limited by the capacity of the PC's main memory.

## PC SOFTWARE INSTALLATION

Installation of software is very simple: double click the setup.exe file and follow the steps. Make sure you are running the program under the administrator accounts of your windows PC platform. Otherwise the graphic function might not be working when graph display mode is needed to display all history data.

If you run the program for the first time, the current weather display will be displayed and at the sub line of the window, the program will show related information regarding the read of all history data into the PC. Please note however, when there is large amount of data is being uploaded, it will take a few minutes time before the system can respond to your setup settings. Otherwise it will display “read weather data fail” error message since the USB port is reading the data from the memory and the system is not able to respond any further job tasks.

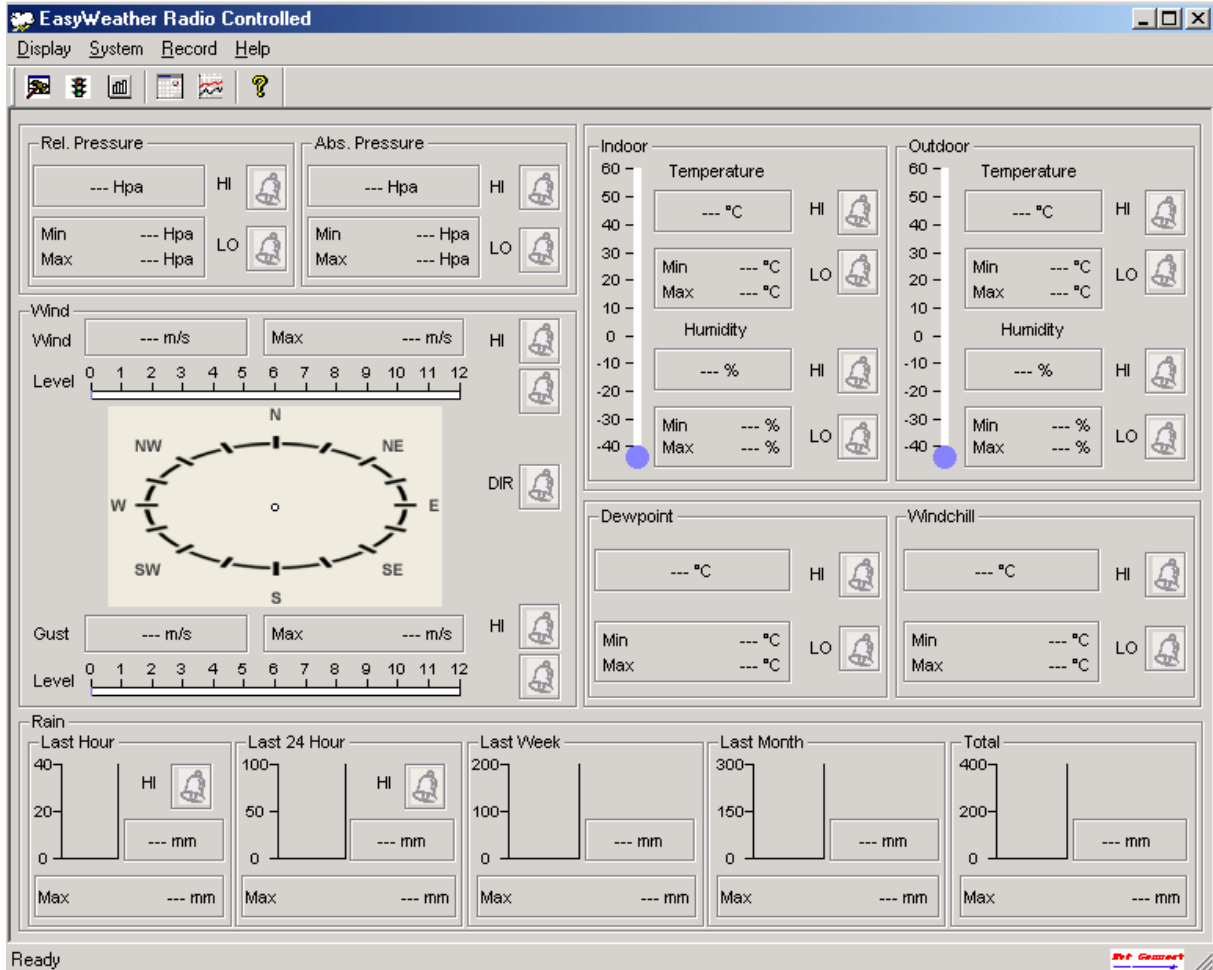

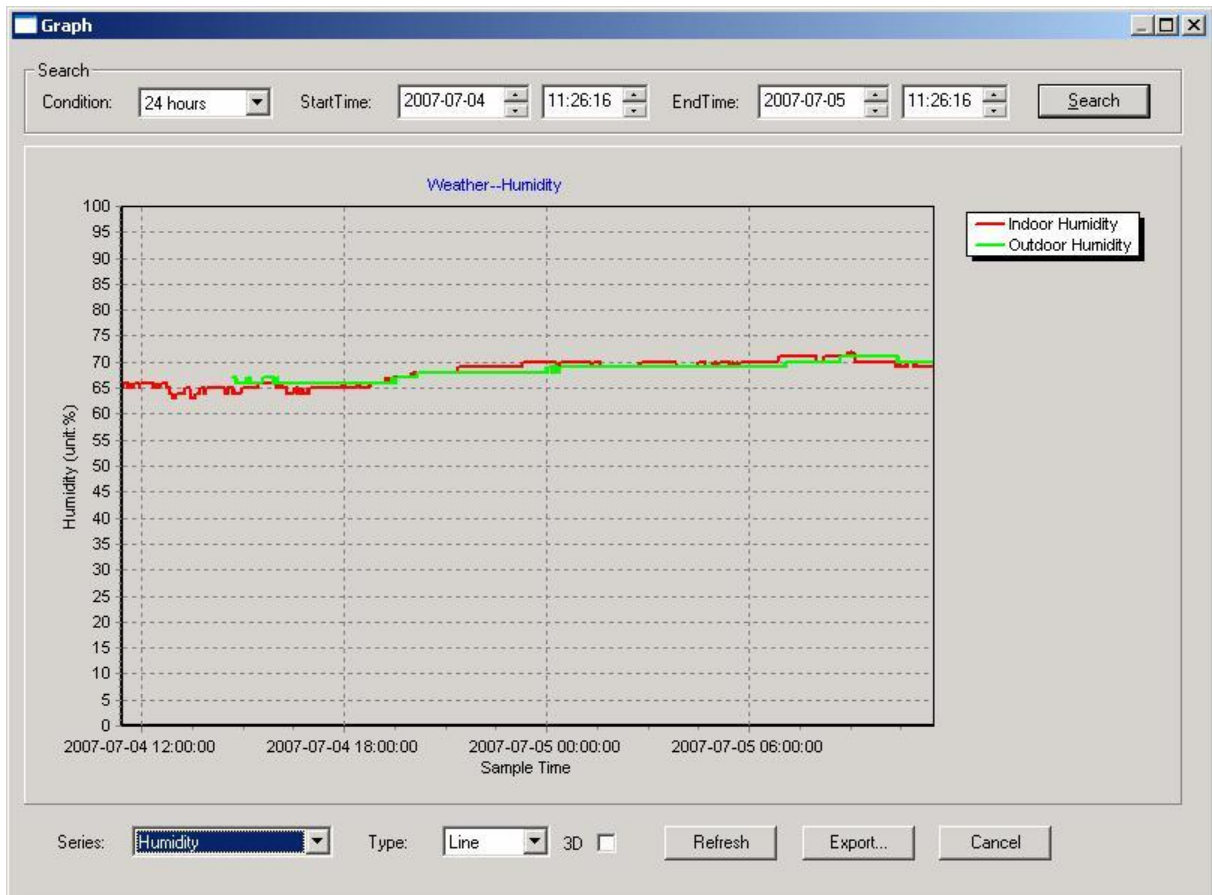

When memory is full, it will take about two minutes to upload all history data into PC and it takes another two minutes to process all history data for graphic display.  
 Further detailed PC software user manual can be found from the help menu.

# SPECIFICATIONS

## Outdoor data

Transmission distance in open field :	100m(300 feet)
Frequency :	433MHz
Temperature range :	-40°C--65°C (-40°F to +149°F)
Accuracy :	+ / - 1 °C
Resolution :	0.1°C
Measuring range rel. humidity :	10%~99%
Accuracy :	+/- 5%
Rain volume display :	0 – 9999mm (show --- if outside range)
Accuracy :	+ / - 10%
Resolution :	0.3mm (if rain volume < 1000mm) 1mm (if rain volume > 1000mm)
Wind speed :	0-160km/h (0~100mph) (show --- if outside range)
Accuracy:	+/- 1m/s (wind speed< 10m/s), +/-10% (wind speed > 10m/s)
Measuring interval thermo-hygro sensor:	48 sec
Water proof level :	IPX3

## Indoor data

Measuring interval pressure / temperature :	48 sec
Indoor temperature range :	0°C--50°C (32°F to + 122°F) (show --- if outside range)
Resolution :	0.1°C
Measuring range rel. humidity :	10%~99%
Resolution :	1%
Measuring range air pressure :	300-1100hPa (8.85-32.5inHg)
Accuracy :	+/-3hpa under 700-1100hPa
Resolution :	0.1hPa (0.01inHg)
Alarm duration :	120 sec

## Power consumption

<b>Base station :</b>	2XAA 1.5V LR6 Alkaline batteries
Remote sensor :	2xAA 1.5V LR6 Alkaline batteries
Battery life :	Minimum 12 months for base station, Minimum 24 months for thermo-hygro sensor

## Remark:

Where outdoor temperature is lower than -20°C make sure proper type of batteries to be used to assure that the device can get enough power to maintain its function properly. Normal alkaline batteries is not allow to be used since when outdoor temperature is lower than -20 °C the battery's discharging capability is greatly reduced.



**Please help in the preservation of the environment and return used batteries to an authorized depot.**

All rights reserved. This handbook must not be reproduced in any form, even in excerpts, or duplicated or processed using electronic, mechanical or chemical procedures without written permission of the publisher.

This handbook may contain mistakes and printing errors. The information in this handbook is regularly checked and corrections made in the next issue. We accept no liability for technical mistakes or printing errors, or their consequences.

All trademarks and patents are acknowledged.

# EASYWEATHER PC SOFTWARE USER MANUAL

## 1. GENERAL INFORMATION

This Weather Station is a high quality, easy to use weather monitoring system which reads, displays and records the weather data from internal as well as external sensors. Besides the internally measured values for indoor temperature, indoor humidity and air pressure the outdoor sensor will take data for temperature and humidity, wind and rainfall. Operation of these units is by wireless transmission to the Base Station.

After installing the “EasyWeather” program on this CD-ROM, your PC can display all indoor data as well as the weather data from the Base Station received from the external sensors. For operation, simply use the USB cable supplied and connect the Base Station to the PC. From now on you can start to track current and history weather information at your finger tips.

## 2. SYSTEM REQUIREMENTS

To install the "EasyWeather" software onto your PC, the minimum requirements are as follows:

Operating System: Windows NT4 (Service Pack >= 6a), Windows 2000, Windows XP, Windows Vista, Windows 7.

Internet Explorer 6.0 or above

Processor: Pentium III 500 MHz or above

Memory: at least 128MB, 256MB recommended

CD-ROM Drive

Base Station and PC must be connected by USB cable

## 3. INSTALLATION OF THE “EASYWEATHER” SOFTWARE

Firstly, the Base Station and the Outdoor Sensors should be connected and checked for correct function (see **Operation Manual** for setting up the Weather Station). After successful checking, install the “EasyWeather” software as follows:

1. Switch on your PC and insert the CD-ROM into the CD-ROM Drive.
2. Double click “Setup.exe”
3. Select the installation process language option and click next
4. Click next and select the destination folder (change directory when needed)
5. Click next and the software will be installed automatically
6. Press ok to finish the installation process
7. From “Start—All Programs—EasyWeather” path and double click the “EasyWeather” icon to start Application

**Note:** The graphic function needs the software to be installed under the administrator account. If it is installed under limited user accounts, the graphic function of the software might not be working correctly.

## 4. BASIC SETTINGS OF THE “EASYWEATHER” SOFTWARE

After the “EasyWeather.exe” program has been started, the following main window will appear on the PC screen:

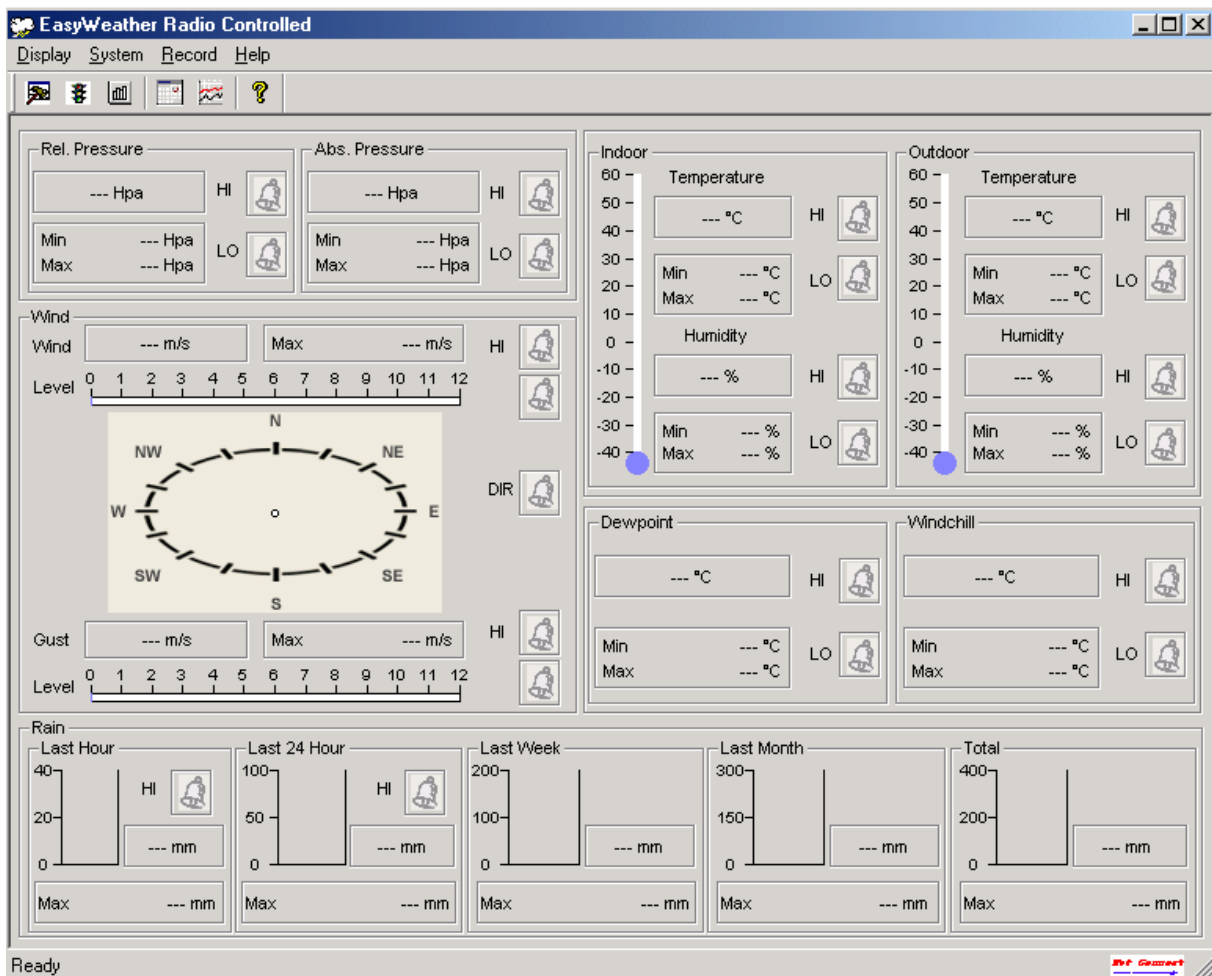

All the settings from the base unit is mirrored into the PC software, so once you have done your setting on the base unit, then you don't need to make any setting changes on the PC software. However you can still easily make any setting changes you wanted from the PC and download the changes into the base station (the setting change will be refreshed when next full minute arrives on the base station).

When base unit is connected to PC, the icon of  will be displayed. If no base station is connected, then  will be displayed.

Function button:



: Display and setup system configuration

**Setup**

Time Zone: [Dropdown]

Interval: [Text] Minute

**Unit**

Indoor Temperature: [Dropdown] °C

Outdoor Temperature: [Dropdown] °C

Pressure: [Dropdown] Hpa

Wind Speed: [Dropdown] m/s

Rainfall: [Dropdown] mm

**Display**

Format: [Dropdown] Full Date

Day: [Dropdown] mm-dd-yy

Time: [Dropdown] 24H

Axis: [Dropdown] 12 Hours

Outdoor Temperature: [Dropdown] Temperature

Pressure: [Dropdown] Absolute

Velocity: [Dropdown] Wind

Rainfall: [Dropdown] Hour

**Alarm Enable**

<input type="checkbox"/> Time	<input type="checkbox"/> Wind Direct		
<input type="checkbox"/> Indoor Humidity Low	<input type="checkbox"/> Indoor Humidity High	<input type="checkbox"/> Outdoor Humidity Low	<input type="checkbox"/> Outdoor Humidity High
<input type="checkbox"/> Indoor Temperature Low	<input type="checkbox"/> Indoor Temperature High	<input type="checkbox"/> Outdoor Temperature Low	<input type="checkbox"/> Outdoor Temperature High
<input type="checkbox"/> Windchill Low	<input type="checkbox"/> Windchill High	<input type="checkbox"/> Dewpoint Low	<input type="checkbox"/> Dewpoint High
<input type="checkbox"/> Absolute Pressure Low	<input type="checkbox"/> Absolute Pressure High	<input type="checkbox"/> Relative Pressure Low	<input type="checkbox"/> Relative Pressure High
<input type="checkbox"/> Wind Speed High	<input type="checkbox"/> Gust Speed High	<input type="checkbox"/> Hour Rainfall High	<input type="checkbox"/> Day Rainfall High

**Pressure**

Relative: [Text] Hpa

Absolute: [Text] Hpa

[Save] [Cancel]

This section is used to set up PC software display, base station units, as well as able or disable the corresponding alarm function. Once you made your choice, press Save to make the setting effective.



: Display and setup system alarm value

**Alarm**
✕

**Time**  
 Hour:  Minute:

**Indoor Humidity**  
 High:  % Low:  %

**Outdoor Humidity**  
 High:  % Low:  %

**Indoor Temperature**  
 High:  °C Low:  °C

**Outdoor Temperature**  
 High:  °C Low:  °C

**Windchill**  
 High:  °C Low:  °C

**Dewpoint**  
 High:  °C Low:  °C

**Absolute Pressure**  
 High:  inHg Low:  inHg

**Relative Pressure**  
 High:  inHg Low:  inHg

**Wind**  
 High:  km/h  bft

**Gust**  
 High:  km/h  bft

**Rain**  
 High Hour:  mm High 24 Hour:  mm

**Wind Direct**

This section is used to set the desired time, high or low alarm value for the base unit. Once you made your choice, choose Save to make the setting effective. If you don't want to make any change, just press Cancel and exit without change.

: Display min and max recorded value

Scope			
Indoor Humidity		Outdoor Humidity	
Maximum	Time	Maximum	Time
76 %	2007-01-02 11:14	78 %	2007-01-03 23:48
Minimum	Time	Minimum	Time
63 %	2007-01-02 15:04	57 %	2007-01-02 08:20
Indoor Temperature		Outdoor Temperature	
Maximum	Time	Maximum	Time
34.0 °C	2007-01-02 16:12	45.8 °C	2007-01-01 12:02
Minimum	Time	Minimum	Time
28.9 °C	2019-05-24 13:14	27.4 °C	2007-01-02 18:40
Windchill		Dewpoint	
Maximum	Time	Maximum	Time
45.8 °C	2007-01-01 12:02	39.8 °C	2007-01-01 12:02
Minimum	Time	Minimum	Time
27.4 °C	2007-01-02 18:40	19.8 °C	2007-01-03 15:27
Absolute Pressure		Relative Pressure	
Maximum	Time	Maximum	Time
29.59 inHg	2007-01-02 04:51	29.86 inHg	2007-01-03 12:25
Minimum	Time	Minimum	Time
29.34 inHg	2019-05-28 16:09	29.47 inHg	2007-01-03 12:51
Wind		Gust	
Maximum	Time	Maximum	Time
9.7 km/h	2007-01-02 19:18	84.6 km/h	2007-01-03 12:05
Rain Maximum		24 Hours	
Hour	Time	0.0 mm	Time
0.0 mm	2007-01-03 11:14	0.0 mm	2007-01-03 11:14
Week	Time	Month	Time
0.0 mm	2007-01-03 11:14	0.0 mm	2007-01-03 11:14
Total	Time	OK	
0.0 mm	2007-01-03 11:14		

This section is used to display the recorded min and max value recorded with time stamp. Min/Max reset can only be done through key operation on the base station.



: display listed history data

No	Time	Interval(mi)	Indoor Humidity(%)	Indoor Temperature(°C)	Outdoor Humidity(%)	Outdoor Tem
34	2007-07-10 11:59	1	65	32.8	65	32
35	2007-07-10 12:00	1	65	32.8	65	32
36	2007-07-10 12:01	1	65	32.8	65	32
37	2007-07-10 12:02	1	93	33.5	65	32
38	2007-07-10 12:03	1	93	33.5	65	32
39	2007-07-10 12:04	1	93	33.5	65	32
40	2007-07-10 12:05	1	95	34.1	65	32
41	2007-07-10 12:06	1	95	34.1	65	32
42	2007-07-10 12:07	1	95	34.1	65	32
43	2007-07-10 12:08	1	95	34.1	65	32
44	2007-07-10 12:09	1	94	34.0	65	32
45	2007-07-10 12:10	1	95	34.3	65	32
46	2007-07-10 12:11	1	90	33.9	65	32
47	2007-07-10 12:12	1	96	34.0	65	32
48	2007-07-10 12:13	1	92	33.4	65	32
49	2007-07-10 12:14	1	93	33.6	64	32
50	2007-07-10 12:14	1	84	33.0	64	32
51	2007-07-10 12:15	1	74	32.9	64	32
52	2007-07-10 12:16	1	70	33.0	64	32
53	2007-07-10 12:17	1	66	33.1	64	32
54	2007-07-10 12:18	1	66	33.1	64	32
55	2007-07-10 12:19	1	65	33.1	64	32
56	2007-07-10 12:20	1	65	33.1	64	32
57	2007-07-10 12:21	1	64	33.1	64	32
58	2007-07-10 12:22	1	64	33.1	63	32
59	2007-07-10 12:23	1	63	33.0	63	32
60	2007-07-10 12:24	1	63	33.0	63	32
61	2007-07-10 12:25	1	63	33.0	63	32

This section is used to display recorded history data in a spread sheet. If you wanted to see all history data in a desired time period, choose the time duration and press Search to reload the history data. With the Export button, you can export the selected history data into text format file for other application purpose.

When the memory of the base station is full, press “Clear Memory” button to refresh the memory space on the base station (remember to upload all data before pressing this button). If you wanted to start a new weather history record, press “Clear Data” button to clear up the data base, all history weather data will be deleted (if you would like to keep a back up history file before deleting all weather data, you can make a copy of the “EasyWeather.dat” file into another folder or just rename the “EasyWeather.dat” file, such as “Jan-07.dat”, for future reference.



: display history data in graph mode

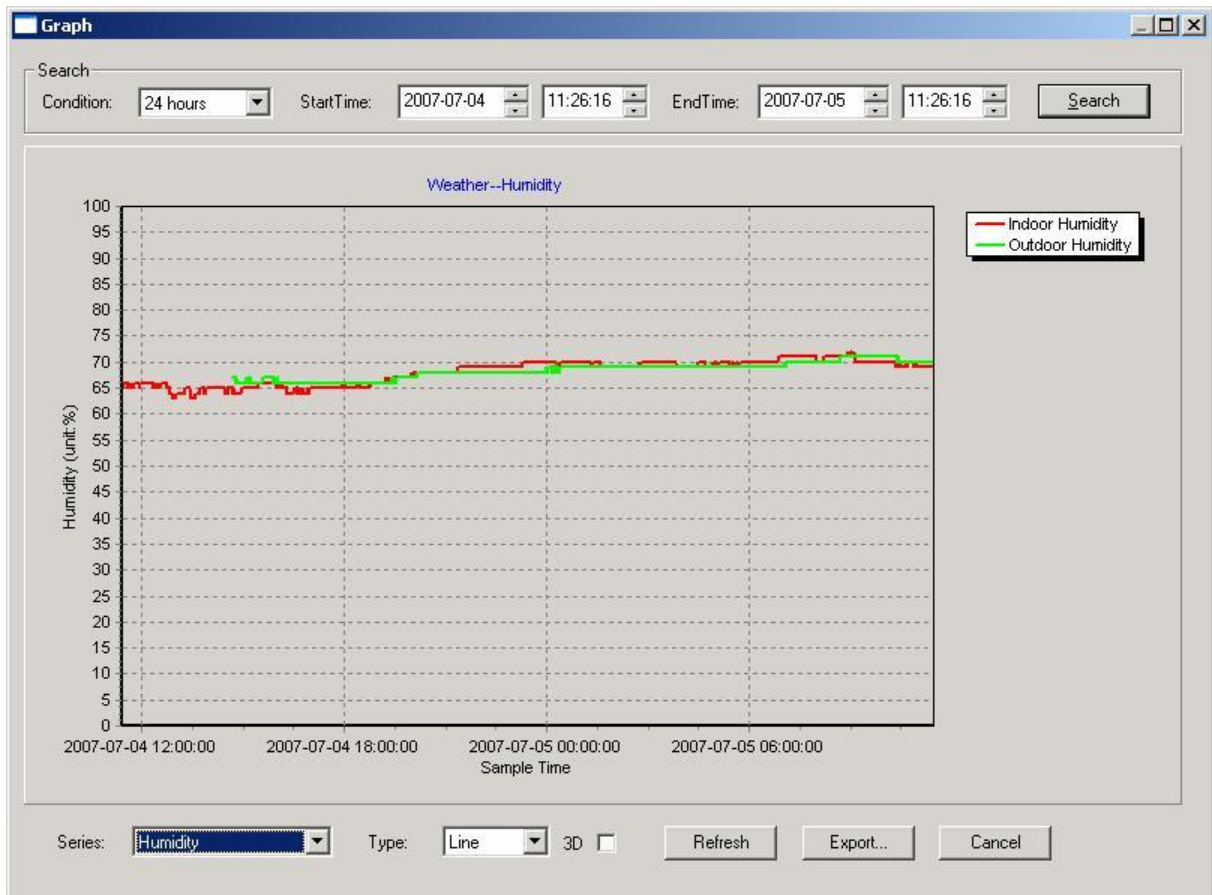

In this section, you can see the history data plotted in graph format for easier observation. If you want to see more details, just use your mouse to select the area you wanted and the display will be automatically updated in more detailed scale:

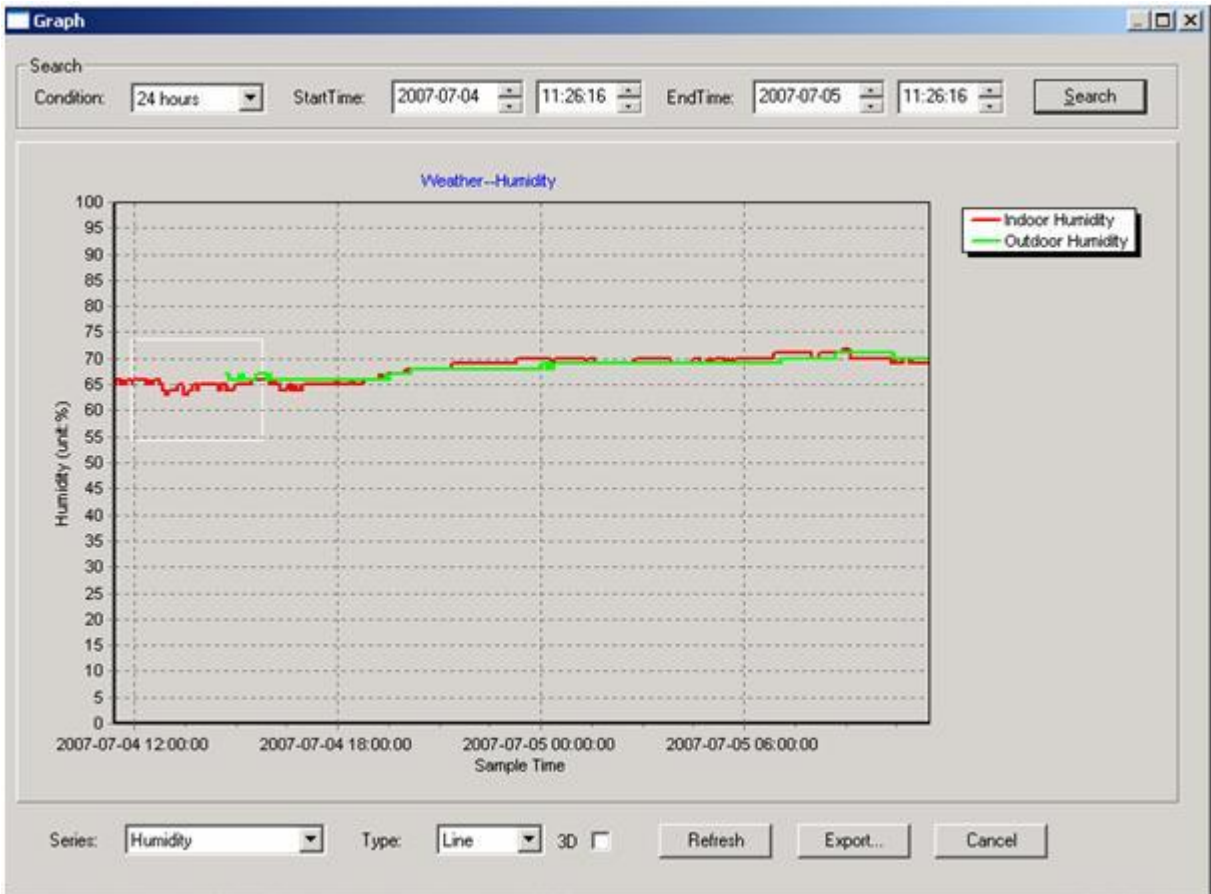

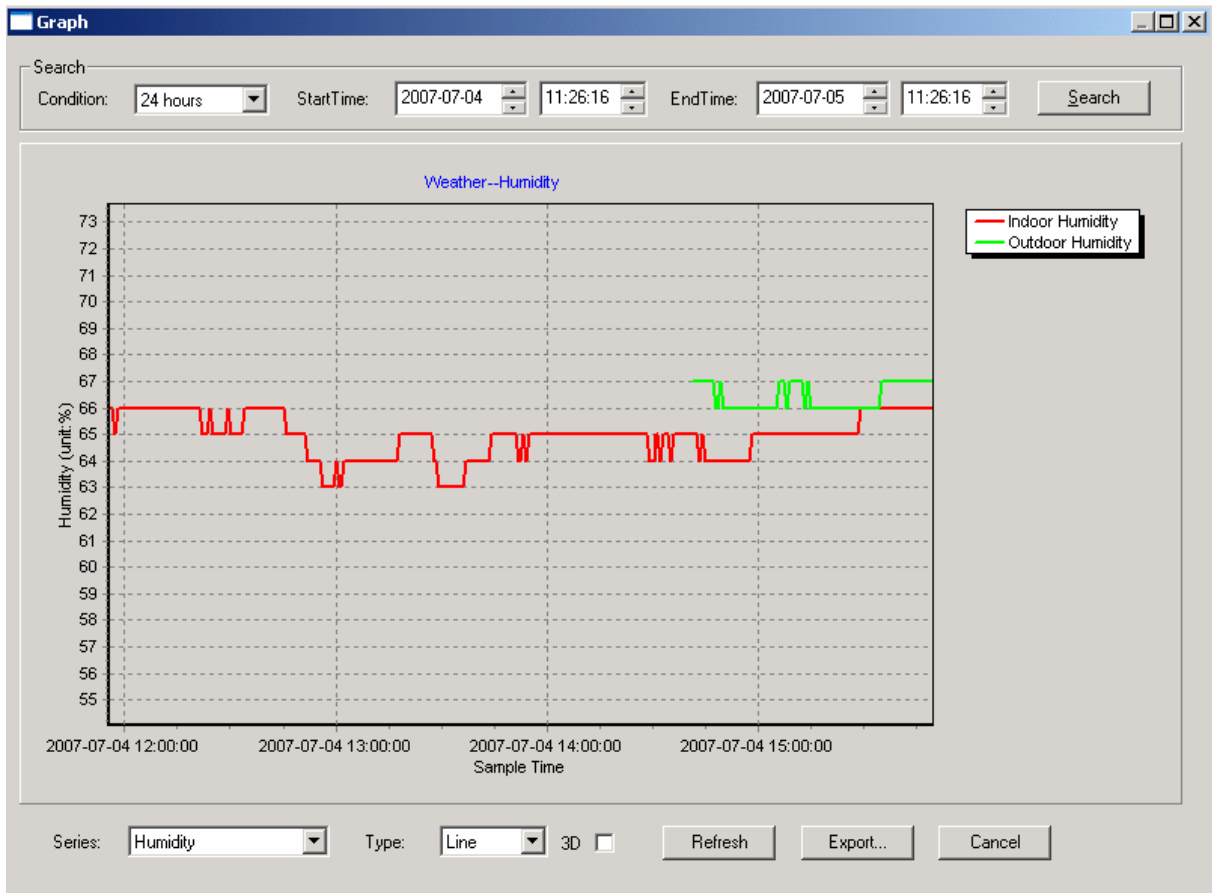

Also you can see the graph in 3D mode by selecting the 3D check box:



You can change the Y axel by scrolling the mouse up and down roller.

### What to do if graph function is not working

This is the most encountered problem with this software. To make the graph function working properly, please check the following step:

1. find the folder where the "EasyWeahter.exe" file is located
2. Create a file name "reg\_graph.bat" file with wordpad or notepad editor program
3. Type "regsvr32 easyweather.ocx" and save the reg\_graph.bat file
4. Double click "reg\_graph.bat" file and it should register the graphic driver again. If successful, then the following window will be displayed:

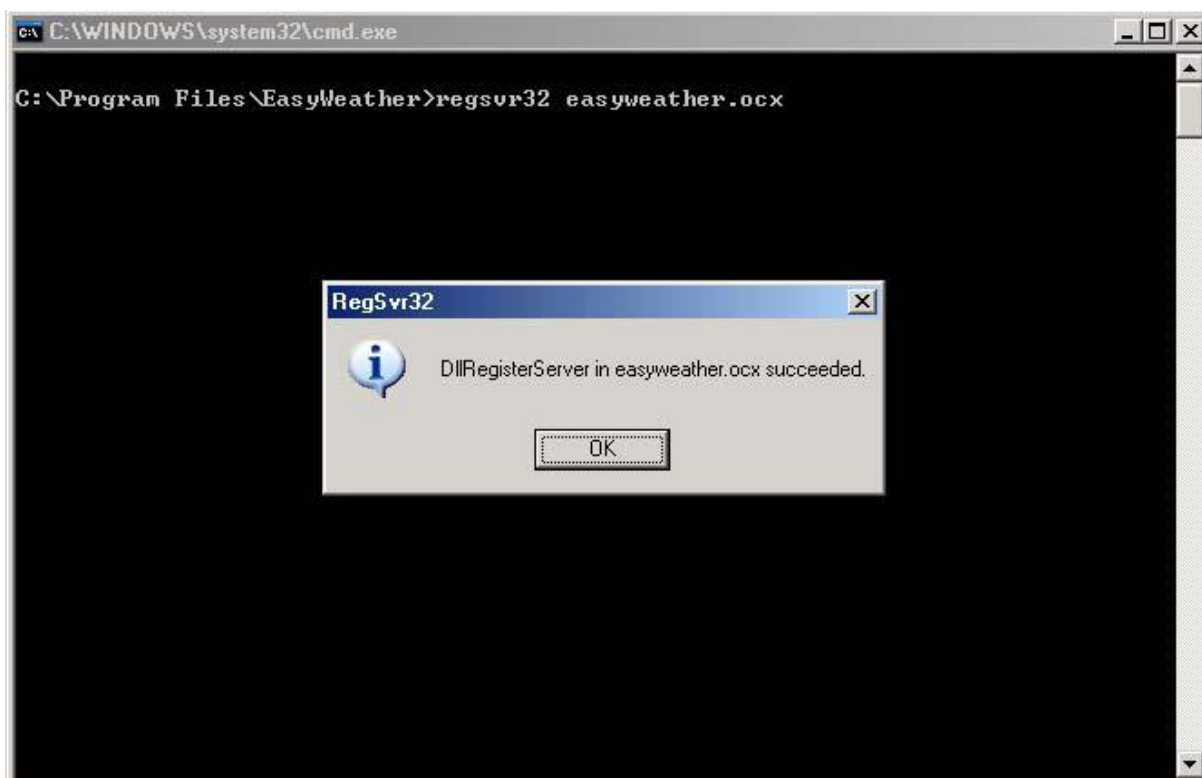

### Special Notes about time synchronization between PC and sub-station:

The PC software obtained its own time scale through the time interval marker from the base station history data, and the PC software automatically synchronizes the weather data with a time stamp calculated. Thus the history data file can have different time when the PC time and base station time is not same. In order to make the time scale correct, remember to set the PC time and base station time same, and further to this, no weather data is allowed to be missed or over-written. If history weather memory on the base station is cleared by manual setting, then the history weather data since last uploading is lost permanently.

Before memory is used up (memory icon on LCD display showing 100% full), remember to upload weather history data to your PC.

If a reset happens for the rain fall on the base station, then there will be rain fall value discrepancy between the PC and the base station.

### Legal Notes

- We reserve the right to delete or change any image whether or not purposely uploaded onto the server by a user of the EasyWeather software products.
- The EasyWeather software products are protected by copyright laws and international copyright treaties as well as other intellectual property laws and treaties.
- You may not copy the printed materials accompanying the products.